

Carriage House Base Cabinet Assembly Instructions

BEFORE ASSEMBLING:

- Carefully read the instructions before starting the installation.
- Empty the carton completely to make sure all pieces are removed, and nothing is discarded.

NOTE: Once the glue dries, it is the glue that holds the cabinet together. The assembly clips (plastic and metal) supplied are for holding the cabinet together until the glue dries.

Parts Overview & List

- A. Side panel (left)
- B. Side panel (right)
- C. Back panel
- D. Bottom Panel
- E. Top Support
- F. Shelf
- G. Drawer
- H. Face frame & doors
- I. Toe Kick

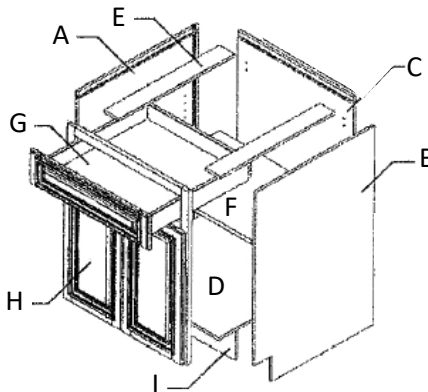

Steps 1-5: Box Assembly

1. Lay cabinet face frame (H) on a clean/soft surface.
2. Apply a light bead of glue into the dado of the face frame (H) where the top side panels (A&B) will be installed.
3. Place the side panels (A&B) firmly into the dados.
4. Block/Clip placement
 - a. Plastic block assembly
 - i. Place the plastic assembly blocks as indicated in the diagram.
 - ii. Place two staples into the plastic assembly blocks on each side, attaching it to the face frame and side panels.
 - b. Metal clips assembly
 - i. Screw the “L-shaped” metal clip into the predrilled spots along the frame of the cabinet.
 - ii. Screw the “flat” metal clip into the predrilled spots on the side panels.
 - iii. Slide each side panel into the dado, making sure the bottoms are perfectly
 - iv. Once in place, attach the sides of the frame using the clips previously installed.
 - v. Fasten clips together using the provided screw in the locking screw hole.

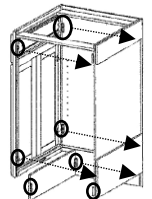
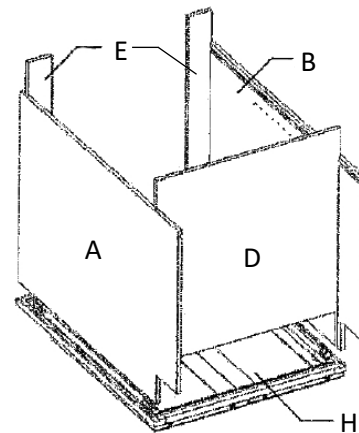

Clip Placement
Clips will be placed on the left and right sides of the inside of the cabinet.

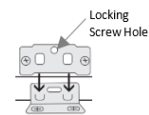

aligned.

5. Apply a light bead of glue to the face frame (E) and the side panels (A&B) where the top and bottom panels (D) install. Slide the top supports (E) and bottom panel (D) into place.

Steps 6-10: Back and Toe Kick Attachment

6. Apply a light bead of glue into the dados that will fit the back panel (C).
 7. Install the back panel (C) by spreading lightly the side panels (A&B) just enough to fit the back panel into the dados.
 8. Screw the back panel to the sides using the pre-drilled holes provided with the screws.
 9. Apply a light bead of glue to both sides of the toe kick (I).
 10. Put a clip on both sides of the toe kick and on the bottom of the side panels (as indicated in the clip placement illustration).
- *See placement instructions for clip or metal clips above.

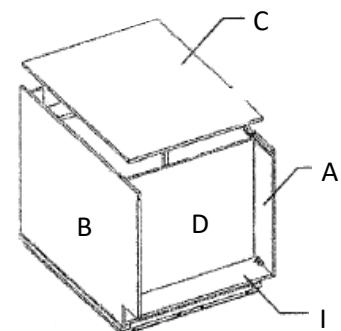

Step 11: Shelf Placement

11. Insert the shelf clip into the holes on the side panels (A&B). Make sure each clip is the same height as the corresponding clips. Each shelf requires 4 clips.
 - a. Base cabinets 12" or more in width will have a ½ depth shelf.
 - b. Pantry cabinets will have 4 shelves.

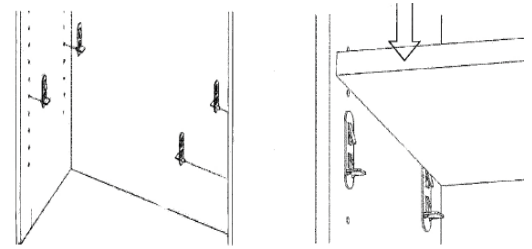

Step 12-19: Drawer Box Assembly

12. Apply a light bead of glue into the dovetail recesses in each drawer component.
13. Press the dovetails of the side panels of the drawer box into the drawer box front, which is preassembled with the drawer header (a rubber mallet could be used to make sure the pieces are firmly together).
14. Apply a light bead of glue into the dado for the drawer bottom panel. Slide the bottom panel into the dados.
15. Apply a light bead of glue into the dovetail of the drawer back panel. Press together as instructed in step 13.
16. Line the locking device for the drawer glide (in the drawer glide box) toward the front of the drawer box. Use the provided stainless screws packaged with the clips to fasten the locking device to the drawer box panel.
17. Find the predrilled holes on the back panel of the cabinet. Place the rear mounting bracket (in the drawer glide box) into the predrilled holes and fasten with the provided screws.
18. Slide the metal drawer glide into the rear mounting bracket. Line the front of the glide so it is flush with the front of the cabinet and fasten with screws. Repeat steps 17-18 on the other side of the cabinet.
19. Line the assembled drawer on top of the metal glides. Push the back of the metal glide into the predrilled hole located on the back of the drawer box. The glide on the locking device will then click together.

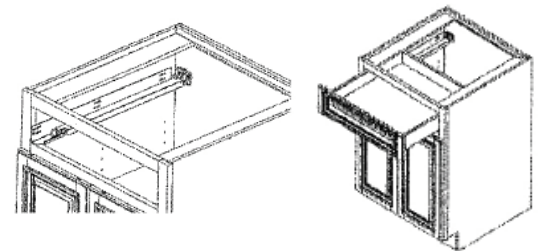
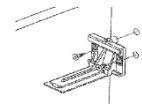
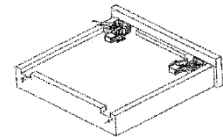
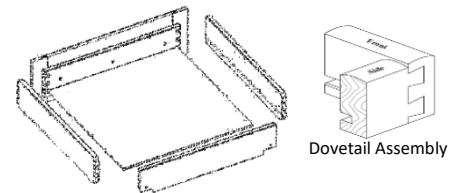

Hinge & Bumper Placement

- Place the door face down, install the hinges, and extend the hinge to the open position. With the hinges in the extended position, attach the door to the face frame of the cabinet. The door can be adjusted using the adjustment screws if necessary.
- Attach the bumpers to the outside corners of the doors and the top corners of the drawers.

